

On/Off Controller - MSCI -LCD



◆ Description ◆

MSCI-LCD displays value of inputs signal and provides C/O contact when the input signal is above set-point A. Model MSCI-2-LCD has 2 output relays and available for DC input signal or temp. sensor PT100.

Model	Input
MSCI-LCD-CDC(VDC)	Cur./ Volt. DC
MSCI-LCD-CAC(VAC)	Cur./ Volt. AC
MSCI-LCD-POT	Potentiometer
MSCI-2-LCD-CDC(VDC) RTD	Cur./ Volt. DC PT-100

◆ Front panel description ◆

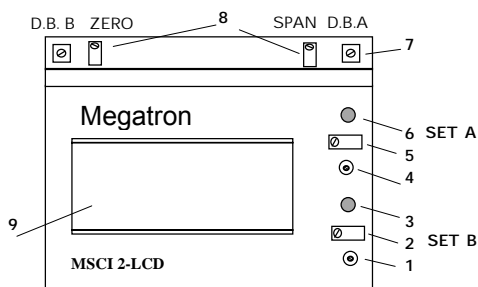

- [1,4] Push-button for displaying the set-point.
- [2,5] Pot. SET A, SET B for set-point setting.
- [3,6] LEDs indicate input is above set-point.
- [7] Pot' D.B. A (D.B. B) for adjusting relay hysteresis
- [8] Pot. Zero and Span for range display adjusting.
- [9] Display

◆ Connections ◆

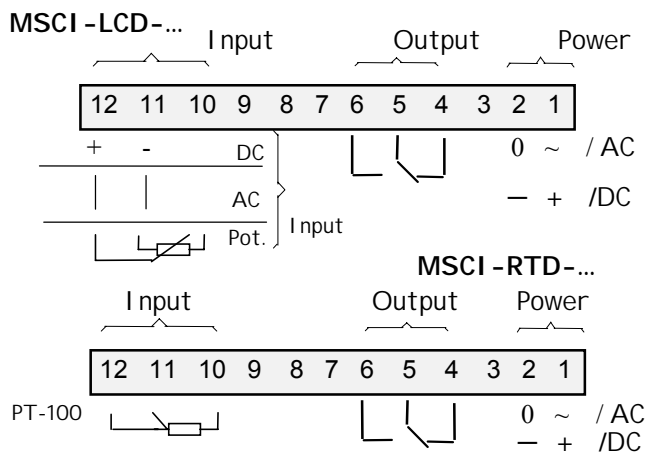

◆ Specifications ◆

- Accuracy:** ±0.25% F.S. or ±1 count, ±0.5% F.S. for AC measuring
- Power supply:** 220VAC or 12/24V DC
- Input:** current / voltage DC /AC, resistance (3 wire) up to 100 KΩ.
(MSCI-RTD - PT-100 temp. sensor only).
(MSCI-2-LCD - current / voltage DC only|PT-100).
- Output:** c/o contact 220V / 5A . Operation mode (FSL or FSH) is selected by internal jumper.
- Ambient Temp.:** -20 ÷ +65 °C
- Display:** 3.5 digits (0-199.9) LCD size 0.5"
- Enclosure:** W70 X L90 X H73 mm plastic case
- Connection:** plug-in terminals
- Mounting:** 35mm DIN-rail

◆ Calibration ◆

The device is calibrated according to customer requirements.

★ Set point A(B) can be adjusted by potentiometer "Set A"(B) located under the plastic front panel (open the plastic cover). Pressing the pushbutton "Set" allows to display set-point value.

★ Min and max display can be adjusted by potentiometers ZERO and SPAN located under the plastic front panel. Adjust 0 by pot' ZERO when input signal is min. Adjust max display by SPAN pot' when input signal is maximum. Repeat calibration.

★ The output relay hysteresis can be adjusted in range 0.5%{10% F.S. by potentiometer "D.B.A (D.B.B)". It's possible to reach the potentiometer through the hole located on the upper area of the front side (see cover removal drawing).

★ The change of the FSH / FSL can be done by internal jumper located on circuit board near relay.

The device is supplied when relay B is in FSL (it means, activated when the input signal is above a set point and released when it is under) and relay A is in FSH.

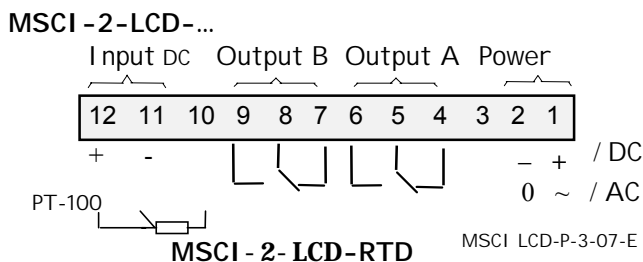
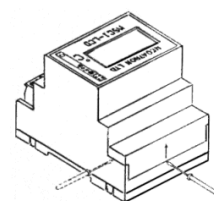

megatron electronics & controls ltd

Manufactures & Representatives for Control Equipment



מגטרון אלקטרוניקה ובקרה בע"מ

יצרנים ומפיצים של ציוד מכשור בקרה והתרעה

Web site: <http://www.megatron.co.il> 31016 חיפה, 1719 ת.ד., 8410705-04 רח' מרקוני 12, 8410704-04 טל