

MMA 182 - 16 Channel Microprocessor Annunciator

◆ Description ◆

The Megatron Microprocessor Annunciator MMA-182 monitors any parameter converted to an electrical signal: level, Temperature, flow, pressure, humidity, voltage, current etc. The Annunciator produces audio and visual alarms when a deviation from the normal occurs.

◆ Specification ◆

Power supply: 220 / 110 VAC or 60 / 24 VDC

Input: Dry contacts or Voltage up to 220 V.
Opto-isolators provide full galvanic isolation between voltage inputs and system.

Output: 75 db internal buzzer,
relay contact for external horn.

Option: "Interlock" - 4 relay contacts for 4 groups

Ambient Temp.: 0 ÷ +65°C

Enclosure: Panel mount box

Size: w109 x h355 and depth 240 mm.
Panel cut out 343 x 100 mm

Connection: plug-in terminals on rear panel

Protection category: IP-51.

◆ Field programming ◆

Some system parameters can be changed by the miniature **BIT-SWITCHES** (E1,E2,M,option: J1,J2) installed on the PCB.

- BIT-SWITCHES **E1** (for 1-8 channels) and **E2** (for 9-16 channels) allow selection of NO/NC or "voltage" / "no voltage" mode. One BIT of switches E1 and E2 are for one input .

Voltage inputs:

Type of input	Description	BIT position
Voltage	Voltage input is at normal and absence voltage is alarm.	OFF
No voltage	No voltage input is at normal and existing voltage is alarm.	ON

Dry contacts inputs:

Type of input	Description	BIT position
NO	NO contact is at normal and NC is alarm.	ON
NC	NC contact is at normal and NO is alarm.	OFF

- Option: the MMA-182 has 4 "interlock output relays" A,B,C and D with a change-over dry-contact. The relays (each - for a group of 4 inputs) will operate at normal condition and will release at an abnormal condition of one or more selected Inputs. The relay will be selected by BIT-SWITCHES **J1** and **J2**:

Channels	1-4	5-8	9-12	13-16
Relay	A	B	C	D
BIT SWITCH	J1		J2	
	BIT 1-4	BIT 5-8	BIT 1-4	BIT 5-8

ON = selected,
OFF = unselected.

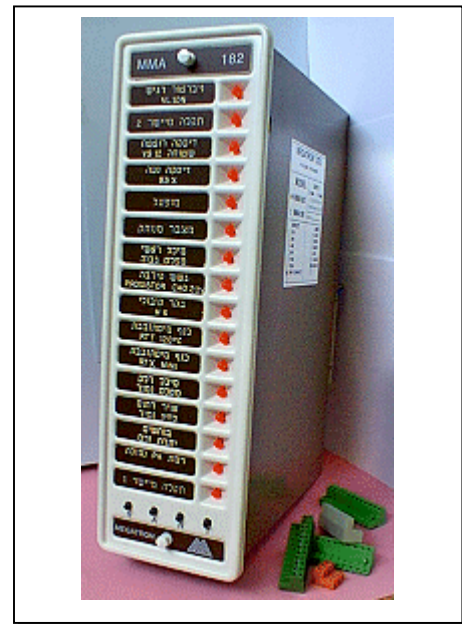

◆ Panel description ◆

[1] LED indicates an alarm position.
[2] Tagging plate to be stuck. 2 lines of 24 characters can be engraved on each plate identifying the input.

[3] Push-buttons: S – Silence. Horn stops without stopping the flashing light;

A - Acknowledgment - stops the flashing and horn;

R - Reset - returns the system to the normal position at mode ISA2B, F.O.A.;

T -Test - functional.

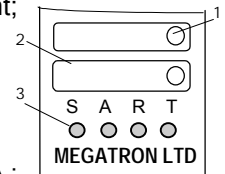

MMA182-S-2-03-E

megatron electronics & controls ltd
Manufactures & Representatives for Control Equipment



מגטרון אלקטרוניקה ובקרה בע"מ
יצרנים ומפיצים של ציוד מכשור בקרה והתרעה

Web site: <http://www.megatron.co.il> 31016 חיפה , 1719 ת.ד. , 04-8410705 רח' מרקוני 12, פקס. 04-8410704, טל. 04-8410704

- "Latch" mode (momentary alarms) can be selected by BIT-SWITCH **M** (BIT1-4). While the system is in "Latch" the MMA will remain at it's last position, it means flashing and horn activate even when the alarm returns to normal. **A** button will stop the light and the horn. In "No-Latch" mode the horn and the light will stop operating automatically when alarm returns to normal.

Channels	1-4	5-8	9-12	13-16
BIT Switches M	BIT1	BIT2	BIT3	BIT4

OFF = "Latch" mode
ON = "No-Latch" mode

- Alarm sequences (modes).

The MMA can operate at 3 different modes selected by BIT-SWITCH **M** (BIT5-6):

- ISA1 sequence is used for monitoring parameters that do not depend one on the others. On "alarm condition" the suitable LED flashes (Fast-flashing) and the horn buzzes. The operator can stop the horn or, in addition, transfers the LED to a "Steady-On" light if the alarm exists or to "OFF" if the channel returns to normal.
- ISA2B sequence is used to be informed when the channel returns to it's normal condition. The MMA has ISA1 mode for alarm. When the channel returns to normal the LED will flash again "Slow-flashing" mode and the horn will operate for a short time.
- F.O.A. sequence (first out) is used when one alarm can cause other alarms. (For example in a boiler system when there is a "Low Feed-Water Alarm", the boiler will stop and other alarms as: Low Pressure, Low Flow etc. will be at abnormal condition). It is necessary to know which alarm was the first one that began the chain of alarms. In this mode the first alarm at "Fast-flashing" mode and all others at "Slow-flashing" mode.

Resolution time of distinguishing the first alarm is 5 mSec.

ISA sequences	BIT5	BIT6	Alarm
ISA1	ON	ON	Flashing and Horn
ISA2B	ON	OFF	Flashing after channel returned to normal
F.O.A.	OFF	ON	First alarm at Fast-flashing mode

- The Delay is to ignore short insignificant alarms or noises. Delays available for all the channels.

The time can be selected by BIT-SWITCH **M** (BIT7-8):

Delay	BIT7	BIT8
80 msec	ON	ON
300 msec	OFF	ON
800 msec	ON	OFF
1.6 sec	OFF	OFF

◆ Connection ◆

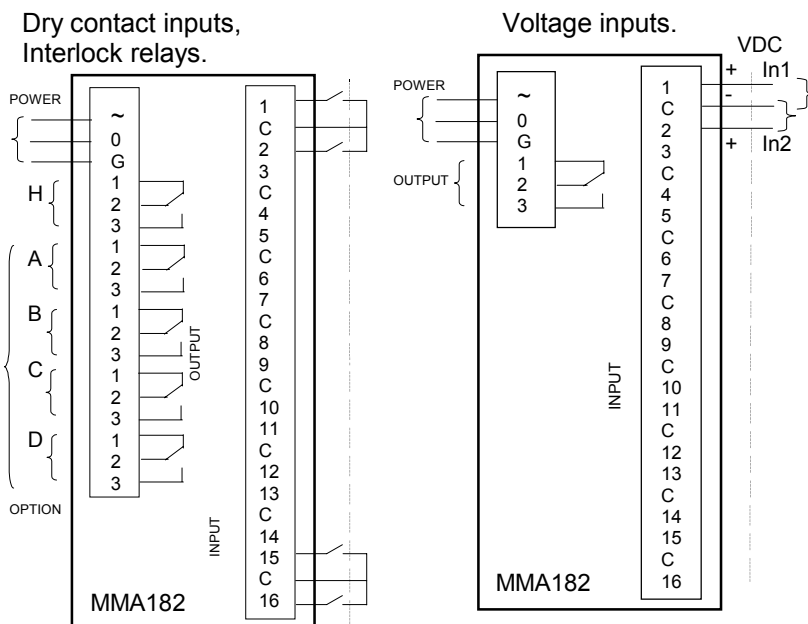

◆ Order ◆

MMA -182 - - -

Power:
220, 110 VAC /
48, 24, 12 VDC

Option: Interlock
R – relay; **0** – without relay

Input:
Dry contact - **S** /
Voltage -
220, 110 VDC/VAC
48, 24 VDC/VAC

Samples:

MMA -182 – 48VAC – 0 – 220VAC
MMA -182 – S – R – 110VAC

MMA182-S-2-03-E

megatron electronics & controls ltd

Manufactures & Representatives for Control Equipment



מגטרון אלקטרוניקה ובקרה בע"מ

יצרנים ומפיצים של ציוד מכשור בקרה והתרה

Web site: <http://www.megatron.co.il>

31016 חיפה , ת.ד. 1719 , רח' מרקוני 12, פקס. 04-8410705 , רח' מרקוני 12, ת.ד. 1719 , חיפה 31016