

# General Operation and Installation Instructions for 4-20mA DC Output Velocity and Acceleration Transducers

## Introduction

These instructions refer to the MTN/1185 Series which is typical of this type of transducer. Please read these general instructions together with the datasheet for the specific transducer you are using such as the 1186, 1187, 1188 and their variants.

These sensors are optimised for measuring vibration in rotating machinery such as motors, gearboxes, pumps, compressors and fans.



Fig 1: MTN/1185CQ Velocity Transducer with integral armoured cable

## Principles of Operation

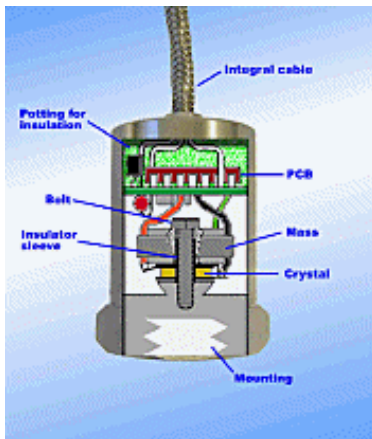

Fig 2: Transducer Construction

Inside the transducer housing a piezoelectric crystal is compressed between the base and a small weight called the seismic mass. When the transducer vibrates along its axis this arrangement applies an alternating force of compression and extension to the crystal. This vibration generates a minute, constantly changing electric charge proportional to the force and thus the acceleration.

When a +24V source is connected, internal microcircuitry conditions this complex alternating charge signal producing a simple DC current signal. This current represents the general level of vibration of the machinery to which the transducer is attached. This DC signal is easy to interpret and use as a control signal to monitor and protect a wide range of machinery from damage due to excessive vibration. The range of the sensor is then represented by a 4-20mA signal, familiar to control engineers and easily read by PLC's and other controllers.

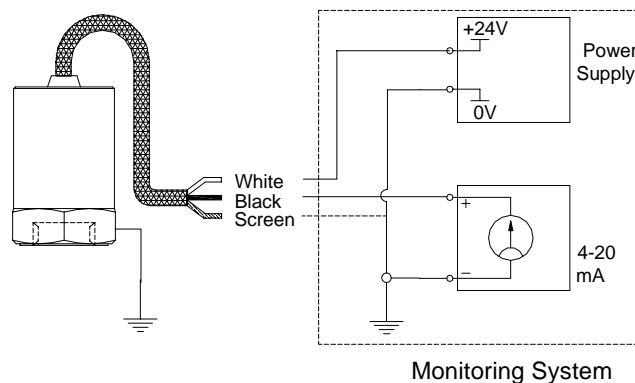

Fig 3: Control Circuit

מגטרון אלקטרוניקה ובקרה בע"מ  
רח מרקוני 12, ת.ד. 25205, חיפה 31251  
טל: 04-8410704, פקס: 04-8410705  
Email: Sales@megatron.co.il

## Electrical

**Connections** - In most models, connection may be by either integral cable or a plug-in connector (3 pin 62GB style). The integral cable type is robust and economic and provides ingress protection to IP66 standard. This avoids the necessity to prepare connector and cable assemblies. Quickfit mounting is preferred for cable versions, see above. Connector versions are convenient when the transducer must be frequently removed from either its mounting or connection to the data system and are therefore suited to an integral stud mounting, 1/4", M8, M10 etc.

**Wiring** - Wiring details are supplied with all transducers on the Calibration Certificate. Observe the polarity of the signal wires when connecting. Integral cable sensors are supplied with stainless steel overbraided, twin core, screened cable for maximum mechanical, thermal and chemical resistance in the machinery area. This may be extended by connecting to equivalent quality non-overbraided cable through a junction box, ensuring that the integrity of the shield is maintained.

**Grounding** - In all Monitran 4-20mA transducers the case is isolated from the electronics and should, in most applications, be grounded to the machine. Ideally, the measuring system should share the same ground as

shown in Fig.6. This arrangement ensures that the case is at the same potential as the electronics and that mains pick-up will not interfere with the signal current. Depending on the electrical environment and the measuring system used, the screen wire may be connected to ground, to the loop -ve (black wire) or left unconnected. If the measuring system is very remote and machine ground is not 'clean' then it may be necessary to isolate the case of the transducer from the machine and connect it to ground at the measurement end using the cable screen wire. Isolation studs are available for this purpose see DS0027.

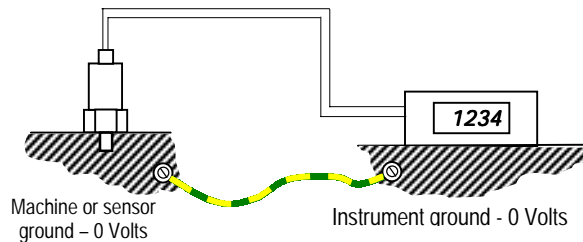

### Cable anchorage

The cable should be fastened at suitable intervals to either a cable tray or convenient supports. This prevents accidental damage by personnel or moving machinery. To avoid excessive bending or axial thrust at the cable entry point or connector, loop the cable back and secure it to the transducer body with a tie-wrap.

**Cable Routing** – Monitran uses high quality shielded, twin-core cables wherever possible to protect the signals well from the effects of ambient electrical disturbances, these show negligible mains pick-up but careful cable routing will minimise potential interference. Avoid running signal cables close alongside AC power cables, radio transmission equipment, motors/ generators and other high current consumption devices. If cable must be extended or joined, ensure that the integrity of the shield is maintained across the join.

### Sensitivity

Various sensitivities are available for specific applications though ranges of 0-20 or 0-25mm/sec are common for machine monitoring applications. The International Standards Organisation ISO10816 gives guidelines for vibration severity on a range of machinery sizes. They may be used as a starting point for selecting sensor range and alarm limits for continuous monitoring systems.

While sensors measuring Velocity are most common (MTN/1185 Series), RMS acceleration "g" may be found useful for monitoring for "out of balance" situations (MTN/1187 Series)

### Mounting

The transducer responds only to vibration along its axis. Care should be taken to ensure that the sensitive axis is aligned with the direction of vibration. This is marked on the transducer on the opposite side to the serial number. However, the transducer can be mounted horizontally, vertically or at any angle between without affecting performance.

The transducer must be firmly mounted on the machine so that vibration is correctly transmitted to the transducer. Loose mounting or bad surface preparation will give rise to resonance or loss of high frequency data. Fixing procedures are described later. Alternatively, for temporary attachment, a range of magnetic adaptors is available, see datasheet DS0051.

Top entry transducers are made in two general formats with either ¼"-28UNF or Quickfit female threads. This allows considerable versatility in mounting to the machine:

- Direct mounting using the ¼" female thread
- Using a variety of magnetic mounts with ¼" male thread
- Inserting a ¼" adaptor to M8, M10 etc
- Using a Quickfit male adaptor with an adhesive base
- Using a Quickfit male adaptor with a male thread: M8, M10, M12 or other thread



*Fig 6: Transducer with Quickfit base showing adhesive and threaded adaptors*

See the appropriate transducer datasheets. For magnetic mounts (DS0051) and for studs and adaptors (DS0027)

Surface preparation is very important. The mounting area should be faced at least 10% greater than the contact diameter of the transducer or adaptor and should be as smooth as possible. Datasheets DS.0090 and DS0092 describe how the mounting should be drilled and tapped for studs and adaptors; Datasheet DS0091 describes adhesive mounting which may be preferred when there is insufficient depth of material to take the length of stud required.

Suitable facing tools (MTN/MH001) and metal filled epoxy adhesive (MTN/MH010) are available from Monitran.

Apply the correct torque as directed in the appropriate transducer datasheet. Over tightening may cause thread damage or shearing of the adhesive layer in adhesive mount transducers. Under tightening will give poor contact, anomalous readings and the transducer may work loose over long periods with high vibration.

**Termination** – Integral cables and cable assemblies will usually be supplied with prepared ends to allow connection to either the measuring system or local junction box. Other connectors are available, call the sales office.

**Mating Connectors** – For connector versions a 3 pin 62GB mating connector is available for users wishing to connect to their own cables, Part Number MTN/MH008.

**Cable Types** – High quality cable is essential to get the best performance from these transducers. The cables used are twin core, shielded, ETFE insulated and stainless steel overbraided. The outside diameter is 4.2mm.

**Permissible Cable Length** – There is rarely a problem with cable lengths with 4-20mA transmitters provided that the total loop resistance does not exceed 600 ohms and that the supply does not drop below 12V.

**Operating Environment** – Standard transducers are stainless steel, all-welded construction and sealed for life with an IP rating of IP66 or IP67 making them immune to high-pressure water jets or occasional immersion for very short periods. They are resistant to water, high humidity, oil, grease and most industrial chemicals. (Check chemical compatibility tables if in doubt.) Standard sensors operate reliably at continuous temperatures up to 90°C with a high temperature option on request to 125°C.

**Dual Output Transducers** - For users requiring both DC output for continuous protection plus an AC output for occasional condition monitoring the MTN/1186 (Velocity/AC acceleration) and MTN/1188 (DC RMS acceleration/AC acceleration) may be selected.

**Submersible Transducers** - Transducers with a "W" in their part number use a high pressure gland to seal around the integral waterproof cable. This makes them suitable for immersion down to depths of 100m and rated at IP68.

**Hazardous Areas** - This series of transducers is strictly for use in non-hazardous areas. Monitran can provide a range of ATEX approved intrinsically safe transducers for hazardous area use.

**Condition Monitoring** – DC output transducers are most useful for continuous monitoring providing a simple 4-20mA output ideal for use with PLC's or data systems. Monitran can provide a wide range of AC output accelerometers for use with frequency analysers, data loggers and on-line analysis systems. Please see our website or request further details.

**Caution** - Monitran uses its best efforts to ensure its products are fully fit for purpose and that any advice is appropriate to the intended use. The user is advised to ensure that all directions are adhered to and the principals of their operation and vibration measurement in general are fully understood. Our warranty terms are available on request.